

# ÜBERSICHTSZEICHNUNG ASSEMBLY DRAWING

# GHOST



## E-TERU UNIVERSAL / ADVANCED (MY21)

Datum: 21-01-2021

Version: 01



E-TERU UNIVERSAL / ADVANCED (MY21)

date: 21-01-2021

version: 01

page 1 / 6

# ÜBERSICHTSZEICHNUNG

ASSEMBLY DRAWING main frame

# GHOST

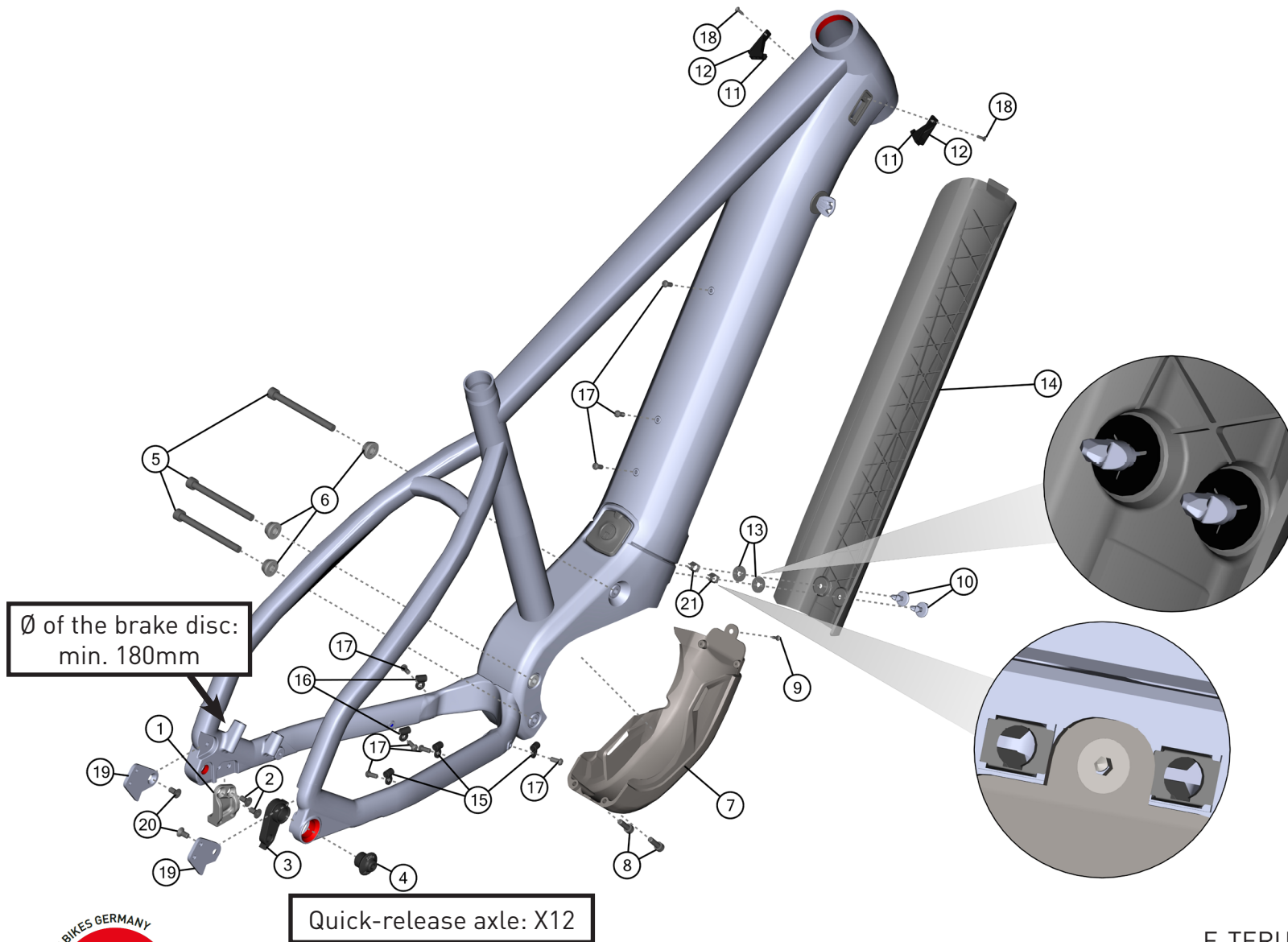

**Hinweis:** Bei den Schrauben muss mittelfeste Gewindegewissicherung verwendet werden. Rote Flächen müssen gefettet werden.

**Note:** use medium strength screw lock for screw threads. red surfaces has to be greased.

# ÜBERSICHTSZEICHNUNG

## ASSEMBLY DRAWING main frame

# GHOST

BOM-ID	Description	Specification	Torque	Item no.	QTY
1	Kickstand Adaptor			SMKS0001	1
2	Counter sunk screw	TX30 - M6 x 13 mm	11 Nm	SMSC0006	2
3	Hanger			FRHG0025	1
4	Hanger nut		20 Nm	FRNT0008	1
5	Hexagon socket screw	IS6 - M8 x 75 mm	22 Nm	FRSC0109	3
6	Cap for hexagon socket screw			FRSC0110	3
7	Motor cover			FRPR0071	1
8	Hexagon socket screw	IS4 - M5 x 20 mm	6 Nm	SM1229	2
9	Counter sunk screw	IS2,5 - M4 x 8 mm	3 Nm	FRSC0090	1
10	Locking pin with handle			FROT0048	2
11	Cable inlets right side			FROT0169	2
12	Cable inlets left side			FROT0170	2
13	Holderplate			FROT0216	2
14	Battery cover			FRPR0072	1
15	Cable guide for 1 cable			SM0002	3
16	Cable guide for 2 cable			SM0263	2
17	Lens head screw	TX25 - M5 x 12 mm	6 Nm	SM0919	8
18	Counter sunk screw	TX10 - M3 x 8 mm	1 Nm	FRSC0072	2
19	Carrier Adaptor right side + left side			SMF0023	1
20	Counter sunk screw	TX30 - M6 x 12 mm	11 Nm	FRSC0064	2
21	Clip			FROT0046	2

# ÜBERSICHTSZEICHNUNG

ASSEMBLY DRAWING battery recording

# GHOST

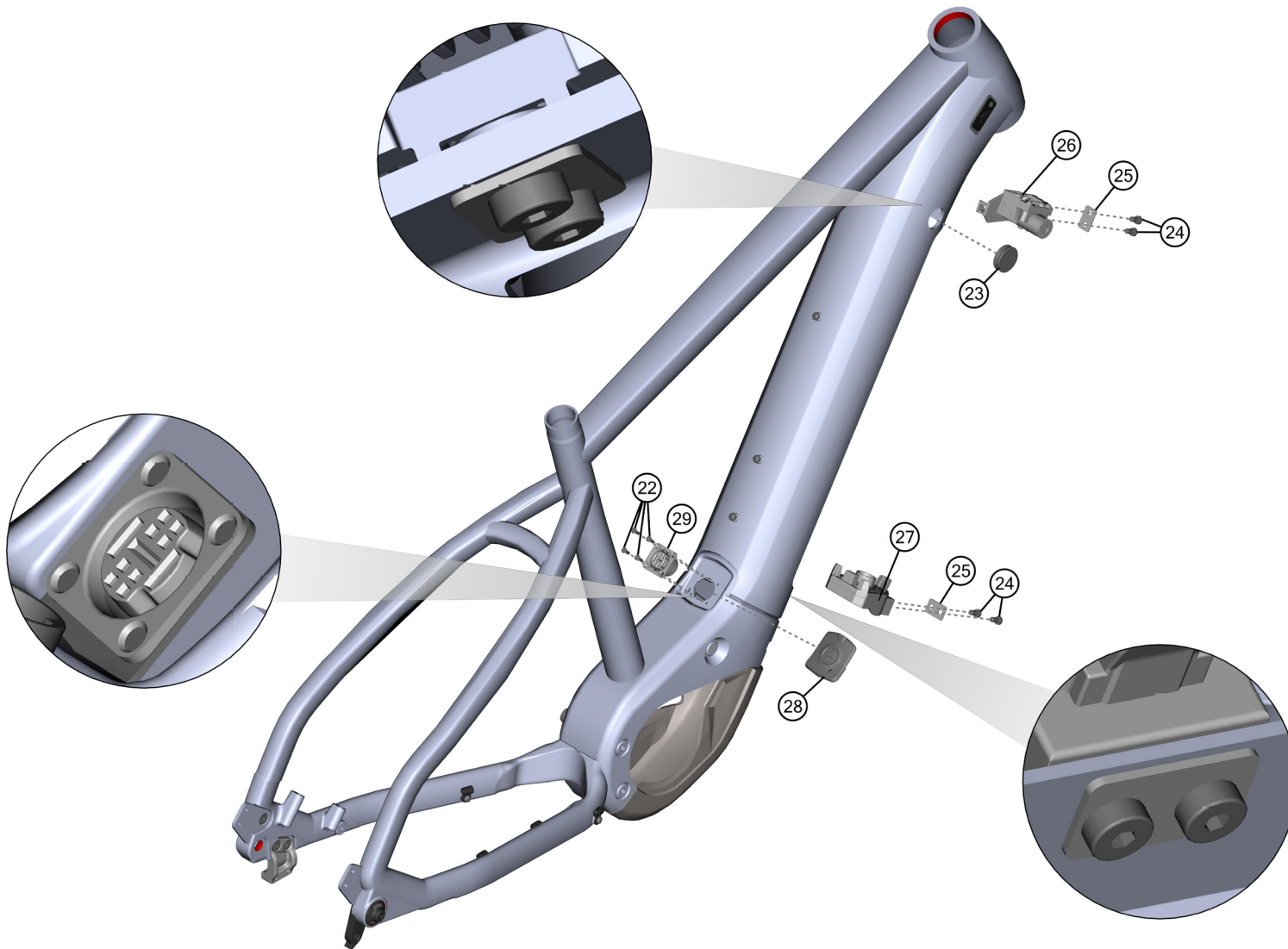

**Hinweis:** Bei den Schrauben muss mittelfeste Gewindegewissicherung verwendet werden.  
Rote Flächen müssen gefettet werden.

**Note:** use medium strength screw lock for screw threads.  
red surfaces has to be greased.

# ÜBERSICHTSZEICHNUNG

## ASSEMBLY DRAWING battery recording

**GHOST**

BOM-ID	Description	Specification	Torque	Item no.	QTY
22	Counter sunk screw	TX10 - M3 x 6 mm	1 Nm	FRSC0114	4
23	Rubber ring			FROT0215	1
24	Hexagon socket screw (flat head)	IS3 - M5 x 16 mm	6 Nm	FRSC0115	4
25	Washer Battery Mount			FRWS0009	2
26	Battery lock			LO0003	1
27	Battery Connector			ELOT0009	1
28	Charge socket port plug			FROT0208	1
29	Charge socket			EL0294	1

# ÜBERSICHTSZEICHNUNG

## ASSEMBLY DRAWING

# GHOST

FACT SHEET:	
SHOCK LENGTH:	-----
SHOCK HARDWARE TOP:	-----
SHOCK HARDWARE BOTTOM:	-----
HEADSET TOP:	ZS 44
HEADSET BOTTOM:	ZS 56
SEATPOST DIAMETER:	31,6 MM
CLAMP INNER DIAMETER:	34,9 MM
BOTTOM BRACKET:	-----
KICKSTAND:	KSA18 (Adapter required)
ISCG STANDARD:	-----
CARRIER MOUNT:	YES (Adapter required)
FENDER COMPATIBLE:	YES

DROPPER SEATPOST READY:	NO
WATERBOTTLE MOUNT:	1x
MAXIMUM PERMISSIBLE TOTAL WEIGHT:	150 KG
MAXIMUM TIRE SIZE:	
WHEEL SIZE:	27,5" / 29"
QUICK RELEASE LENGTH:	169 MM
OVER-LOCKNUT DIMENSION (O.L.D.):	148 MM
FD CLAMP SIZE:	-----
FD TYPE:	-----
ENGINE:	YAMAHA PW-ST
BATTERY:	SIMPLO 630 WH
DISPLAY:	YAMAHA DISPLAY A